

Healthstream

OWNER'S MANUAL

HS16TM



RETAIN OWNER'S MANUAL
FOR FUTURE REFERENCE

The Fitness Generation Pty Ltd
TEG
AUSTRALIA

Service call 1300 796 636

TABLE OF CONTENTS

* SAFETY	-----	p1~p2
* WARM-UP & COOL DOWN	-----	p3
* UNPACKING & ASSEMBLY	-----	p4
* ASSEMBLY DRAWING	-----	p5-p6
* FOLDING INSTRUCTION	-----	p7
* INCLINE MANUAL	-----	p8
* COMPUTER OPERATIONS Control panel function, control panel operation	-----	p9-p12
* BELT ADJUSTMENT	-----	p13
* CARE & MAINTENANCE	-----	p14
* LUBRICATION MAINTENANCE	-----	p15
* TROUBLE SHOOTING	-----	p16-17
* EXPLODED DRAWING	-----	p18
* PARTS LIST	-----	p19-20

SAFETY

IMPORTANT: Read all instructions and warnings before using the treadmill

WARNING! : Do not attempt to use this treadmill with a voltage adapter.
Do not attempt to use this treadmill with an extension cord.

CONSULT A PHYSICIAN IMMEDIATELY

Warning: before starting any exercise program consult your physician. This is especially important for individuals over the age of 35 or persons with pre-existing health problems. Read all instructions before using any fitness equipment. We assume no responsibility for personal injury damage sustained by or through the use of this treadmill.

IMPORTANT SAFETY INSTRUCTIONS

- Obtain a medical exam before beginning any exercise program.
- Keep children and pets away from the treadmill. Disabled persons must be supervised while using the treadmill.
- Stop exercising if you feel faint, dizzy, or experience pain at any time while exercising and consult your physician.
- Clip the SAFETY KEY onto your clothing and carefully test it prior to using the treadmill.
- Disconnect all power before servicing the treadmill.
- Connect the treadmill to a properly grounded outlet only.
- Do not operate treadmill in damp or wet locations.
- This treadmill is for home use only.
- Remove the SAFETY KEY when not in use.
- Do not operate the treadmill if 1. The power cord is damaged; 2. The treadmill is not working properly; 3. The treadmill has been dropped or damaged.
- Inspect the treadmill for worn or loose components before each use.
- Do not use the treadmill outdoors.
- Read and understand this owner's manual completely before using the treadmill.
- Read and understand all warnings posted on the treadmill and in this owner's manual.
- Do not wear loose or dangling clothing while using the treadmill.
- Always wear proper footwear on or around exercise equipment.
- Set up and operate the treadmill on a solid, level surface. Do not operate in recessed areas or on plush carpet.
- Provide the following clearances: 100cm at each side, 200cm at the back and enough room for safe access and passage at the front of the treadmill.
- Do not modify the treadmill in any way.

SAFETY

TARGET HEART RATE ZONE

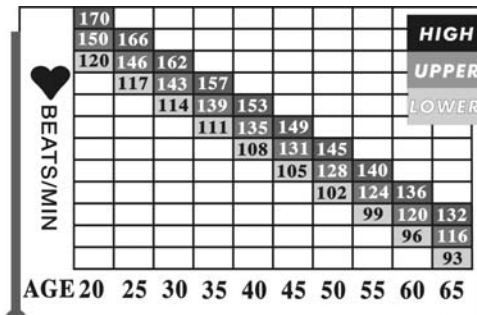

Target Heart Rate Zone
 $220 - \text{your age} = \text{maximum heart zone}$

You do not want to workout at your maximum heart rate. The recommended Heart Rate Zone is a percentage of your maximum heart rate. Between 60% and 75% of your maximum heart rate.

Lower limit of Target Heart Rate Zone = maximum heart rate X 0.6

Upper limit of Target Heart Rate Zone = Maximum heart rate X 0.75

(This is recommended by the American Heart Association. Before starting exercise program, please consult your physician to understand your physical situation)

HOW OFTEN SHOULD YOU EXERCISE:

You should exercise three to four times a week to improve your cardiovascular and muscle fitness.

HOW HARD SHOULD YOU EXERCISE:

Intensity of exercise is reflected in your heart rate. Exercise must be sufficiently rigorous to strengthen your heart muscle and condition your cardiovascular system. Only your doctor can prescribe the target training heart range for you. Before starting any exercise program consult your physician.

HOW LONG SHOULD YOU EXERCISE:

Sustained exercise conditions your heart, lungs and muscles. The longer you are able to sustain exercise within your target heart range, the greater the aerobic benefits.

BEGINNER TREADMILL PROGRAM

	EXERTION LEVEL	DURATION
WEEK 1	Easy	6~12 minutes
WEEK 2	Easy	10~16 minutes
WEEK 3	Moderate	14~20 minutes
WEEK 4	Moderate	18~24 minutes
WEEK 5	Moderate	22~28 minutes
WEEK 6	Slightly higher or slightly lower	20 minutes
WEEK 7	Add interval training	3 minutes at moderate exertion with 3 minutes at higher exertion for 24 minutes

WARM-UP & COOL DOWN

WARM- UP& COOL-DOWN

A successful exercise program consists of a warm up, aerobic exercise, and a cool down. Warming up is an important part of your workout, and should begin every session. It prepares your body for more strenuous exercise by heating up and stretching out your muscles. At the end of your workout, repeat these exercises to reduce sore muscle problems. We suggest the following warm-up and cool-down exercises:

1



Head rolls

Rotate your head to the right for one count, feeling the stretch up the left side of your neck. Next rotate your head back for one count, stretching your chin to the ceiling and letting your mouth open. Rotate your head to the left for one count, and finally, drop your head to your chest for one count.

2



Shoulder lifts

Lift your right shoulder up toward your ear for one count. Then lift your left shoulder up for one count as you lower your right shoulder.

3



Side stretches

Open your arms to the side and continue lifting them until they are over your head. Reach your right arm as far upward toward the ceiling as you can for one count. Feel the stretch up your right side. Repeat this action with your left arm.

4



Inner thigh stretch

Sit with the soles of your feet together with your knees pointing outward. Pull your feet as close into your groin as possible. Gently push your knees toward the floor. Hold for 15 counts.

5



Toe touches

Slowly bend forward from your waist, letting your back and shoulder relax as you stretch toward your toes. Reach down as far as you can and hold for 15 seconds.

6



Quadriceps stretch

With one hand against a wall for balance, reach behind you and pull your right foot up. Bring your heel as close to your buttocks as possible. Hold for 15 counts and repeat with left foot up.

7



Hamstring stretches

Sit with your right leg straight in front of you. Straighten your leg out while trying to hold on to your outstretched leg with your hand. Starting up with your back straight. Slowly exhale and try to bring your chest to the knee of your outstretched leg. Hold, then repeat on the other side for 15 seconds.

8



Calf/achilles stretch

Lean against a wall with your left leg in front of the right and your arms forward. Keep your right leg straight and the left foot on the floor; then bend the left leg and lean forward by moving your hips toward the wall. Hold, then repeat on the other side for 15 seconds.

UNPACKING & ASSEMBLY

WARNING!: Use extreme caution when assembling the treadmill. Failure to do so could result in injury

NOTE: Each step number in the assembly instructions tells you what you will be doing. Read and understand instructions thoroughly before assembling the treadmill.

1. Unpack the carton and place all separate parts outside the carton.
2. Tear open the carton as the picture is showing, fold up the treadmill.
3. Hold on to the roller cover with two hands and move the treadmill forward as the picture is showing.

Failure to follow this procedure may result in serious injury due to the pinch point area on the front frame near the motor cover.

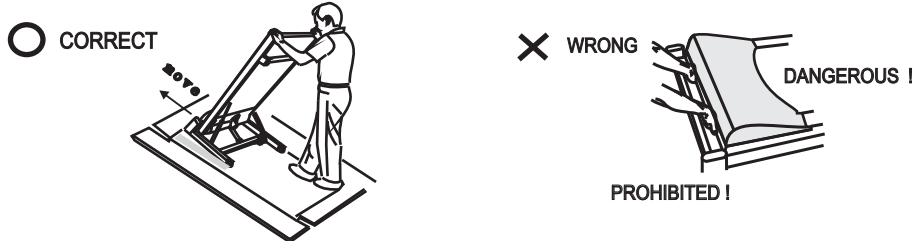

Check the following items are present. If any of the parts are missing, contact 1300796636.

1		10		21		36	
	MAIN FRAME 1pc		SAFETY KEY 1pc		FRONT COVER 2pcs		ALLEN WRENCH 1pc
37		45		48		59	
	SCREW DRIVER 1pc		POWER PLUG 1pc		CHEST BELT 1pc		INNER WASHER 8pcs
63		74		84		87	
	HALF ROUND HEAD HEX BOLT 8pcs		CROSS HEAD SELF TAPPING BOLT 6pcs		MP3 LINE 1pc		ALLEN WRENCH 1pc

ASSEMBLY DRAWING

Step 1

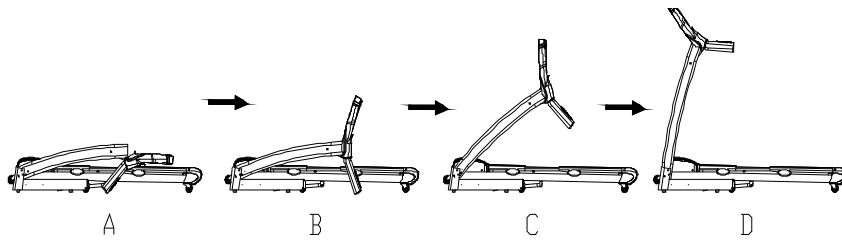

Step 2

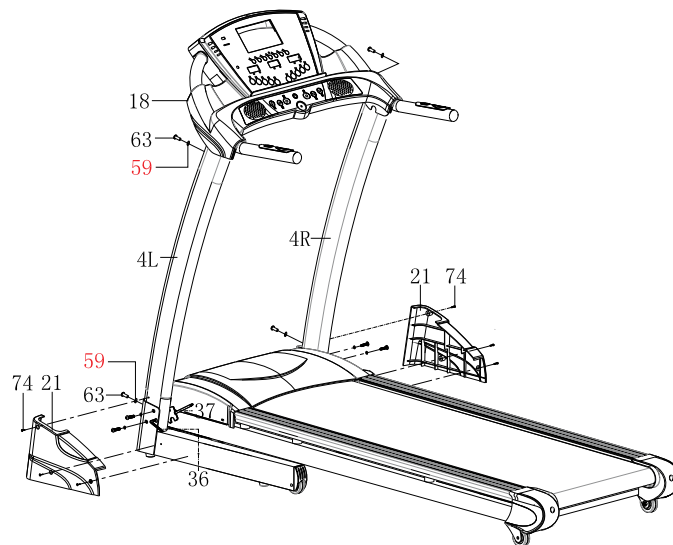

Step 3

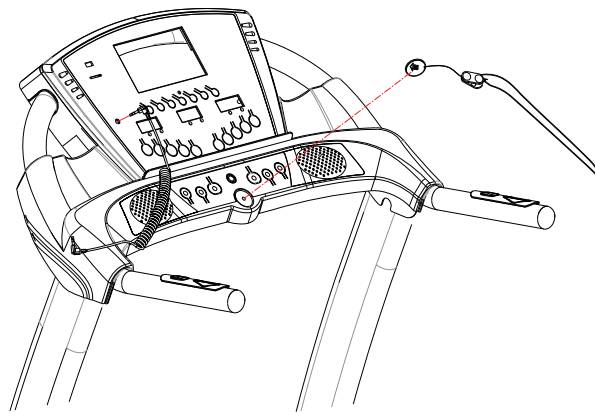

Note: Please check that all of the parts are assembled correctly and the plug is fitted into wall correctly

Folding instruction

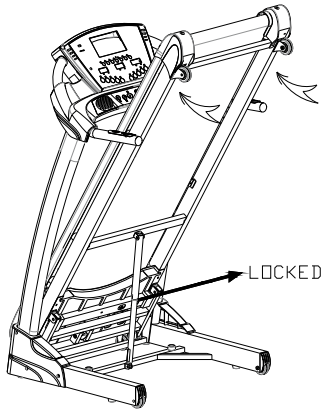

Step 1

Lift up the machine deck and push forward until you hear a "click" which means that the safety casing has locked into the pneumatic cylinder.

Unfolding instruction

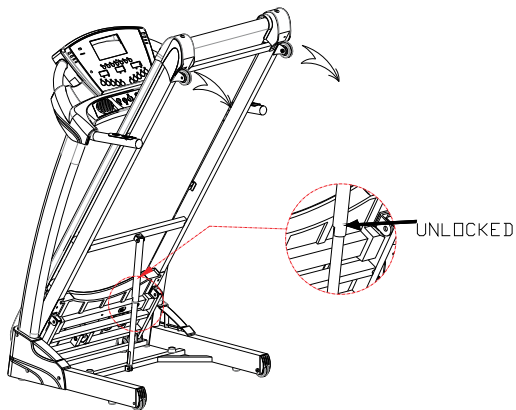

Step 2

Push the deck slightly forward and kick lightly on the center of the pneumatic cylinder. Allow the deck to slowly fall to the floor.

INCLINE MANUAL

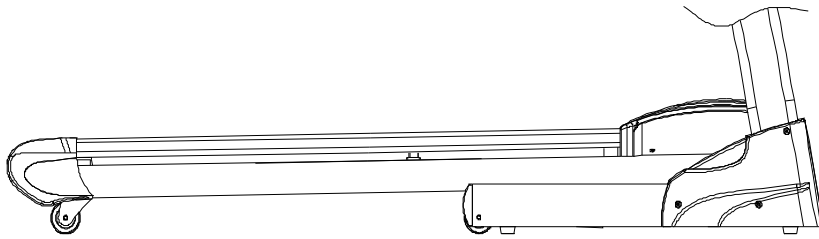

PICTURE 1

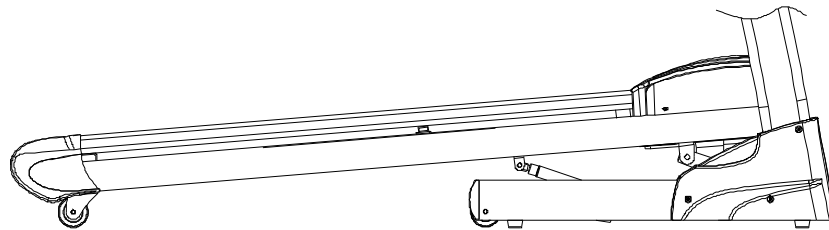

PICTURE 2

INCLINE INSTRUCTIONS:

"INCLINE+"、"INCLINE-" and "+" 、 "-" on left handrail are the incline increase and decrease buttons .

To adjust the incline while the treadmill is running you can also press the incline shortcut keys on the console.

COMPUTER OPERATIONS

CONTROL PANEL FUNCTION

Window display: 1 LCD window

CALORIES: Indicates estimated calories burnt

START: Start the treadmill

PULSE: estimated heart rate

SPEED: Indicates kph in 0.1 increments

STOP: Stop the treadmill

INCLINE: Indicates incline in percent of grade in 1% increments

DISTANCE: Indicates km travelled in 0.1 increment

TIME: Indicates time you workout, can be set to countdown

MODE: Enter programs selection, enter time setting, push 3 seconds for scanning

Prog: Press Prog button and choose from "1.0" manual mode to "P1-P12", "U01-U02", "HRC" and then manual normal model.

Mode: When the treadmill is not running, press the mode button to choose countdown modes: "TIME" "DISTANCE" and "CALORIE" and then normal model

ONE-TOUCH SPEED 3,6,9,12: Used to reach ideal speed

ONE-TOUCH INCLINE 3,6,9,12: Used to reach ideal incline



PROGRAM AND START INSTRUCTION

1. Program instruction

- a): One manual program includes normal mode, time count down mode, distance count down mode, calories count down mode and time normal model;
- b): 12 automatic programs: P01, P02, P03, P04, P05, P06, P07, P08, , , P12;
- c): 2 user ,U1,U2.
- d): 1 HRC program

2. Start instruction

- a): Put the safety key on the holder of the console, beeper beeps once, computer will display, then you are ready to go into the manual mode.
- b): Press the start key, the middle window will indicate 5-4-3-2-1, beeper will beep five times, then you are ready to start your treadmill;

3. Manual Model

- a): Turn on the power, enter normal mode under manual program;
- b): Manual program has 3 settings: time setting, distance setting and calories setting. When you start to enter manual mode the time window indicates 0:00;

- c): By Pressing mode key under manual mode, you can enter into time count down mode. Time window lights up and indicates preliminary time 30:00. Press start to run the machine
- d): Press mode key under time count down mode, enter into distance count down mode. Window lights up and indicates preliminary distance 1.0. Pressing speed +/- you can set distance count down, ranging 1.00-99.00-1.0-...;
- e): Press mode key under distance count down mode, you can enter into calories count down mode. Window lights up and indicates preliminary calories 50. Press speed +/- or incline +/-, you can set calories count down, ranging 20-990CAL...;
- f): Time normal mode: can't be set, just record the treadmill running time
- g): The window will display "END" after stopping the time countdown, distance countdown and calories countdown program.

4. Manual program operation

- a): Press start key, time count down 5 seconds, then treadmill will start to work with initial speed 1km/h;
- b): Press speed+/-, you can adjust speed;
- c): Press incline+/-, you can adjust incline;
- d): Press stop, you can stop treadmill at working state;
- e): Press quick speed key, you can quickly adjust the speed you want ;
- f): Press quick incline key, you can quick adjust the incline you want;
- g): By pulling out safety key, you can stop the treadmill urgently. Speed window indicates "E-07" and beeper warns a second;
- h): When you set the time gradually decreases to zero, speed slows down until stop, Time window indicates END, beeper warns once a second, then display turns back to P0 state;
- i): When you set the distance gradually decreases to zero, speed slows down until stop, distance window indicates END, beeper warns once a second, then display turns back to P0 state;
- j): When you set the calories gradually decreases to zero, speed slows down until stop, calories window indicates END, beeper warns once a second, then display turns back to P0 state

5. Program mode

- a): Press program key, you can enter into automatic program.
- b): Press start key, you can start treadmill at the speed of program set;
- c): Press speed+/-, you can adjust speed;
- d): Press incline+/-, you can adjust incline;
- e): Press quick speed key, you can quickly adjust the speed you want;
- f): Press quick incline key, you can quick adjust the incline you want;
- g): Every program has 16 segments, every segment working time is 1/16 of set time;
- h): When transferring from one segment to another, you'll hear 3 beeps.
- i): Press stop key, you can stop working the treadmill;
- j): When set time gradually decreases to zero, speed slows down until stop, beeper warns a second, then display turns back to P0 state;
- k): Pulling out safety key, you can stop working treadmill urgently. Speed window display "---"

TIME INTERVAL		SET TIME / 10 = EVERY GRADE TIME									
		1	2	3	4	5	6	7	8	9	10
P1	SPEED	3	5	5	10	5	2	3	2	5	3
	INCLINE	0	0	1	1	1	1	2	2	2	0
P2	SPEED	1	7	1	7	12	4	12	4	12	2
	INCLINE	0	1	2	2	3	3	2	2	3	0
P3	SPEED	5	9	4	8	10	12	4	8	4	4
	INCLINE	0	1	2	3	4	5	4	5	4	0
P4	SPEED	3	6	12	12	12	3	3	3	5	2
	INCLINE	0	1	2	3	4	5	6	7	6	0
P5	SPEED	2	12	12	12	3	3	3	3	12	2
	INCLINE	0	2	4	6	4	2	1	0	1	0
P6	SPEED	4	5	6	8	6	8	6	9	6	3
	INCLINE	0	1	3	4	4	3	3	1	2	0
P7	SPEED	4	7	9	4	4	12	4	8	4	2
	INCLINE	0	1	1	3	3	5	5	7	7	0
P8	SPEED	2	6	6	6	12	5	5	5	3	3
	INCLINE	0	2	3	5	4	6	6	8	8	0
P9	SPEED	2	12	2	12	2	2	12	2	2	3
	INCLINE	0	1	3	5	7	9	7	5	3	0
P10	SPEED	4	5	6	8	6	8	6	9	3	3
	INCLINE	0	1	2	4	6	8	6	4	2	0
P11	SPEED	4	5	7	9	6	9	6	10	7	3
	INCLINE	0	1	2	3	4	5	6	7	8	0
P12	SPEED	4	7	10	8	12	6	6	12	12	6
	INCLINE	0	4	8	4	8	4	8	4	8	0

6. User programs:

a). Programs setting: To start press the program until it shows the user program(U1,U2) choose one and enter into setting.

- b). Press "Mode" enter into time set, the range is 5:00-99:00
- c): Press "Mode" again and Go straight to the quick speed or quick set incline button and select your desired speed or incline , press mode and your choice will be set, the next workout segment will flash, go through the same setup as you completed with segment one. You must complete all 10 segments, at the end the computer will flash "OK" , your user program is now saved and ready to use, When using your user program the screen will switch from incline to speed (every 5 seconds) and your set programmed levels will be displayed.

7. Safety key function :

Pull off the safety key, the LCD windows show " ↓ " , the buzzer sound "BIBI-BI" (the data of other windows keep unchanged). the motor will stop moving.

8. The display range of numerical value

TIME : 0:00 – 99.59(MIN)
 DISTANCE: 0.00 – 99.9(KM)
 CALORIES: 0.0 – 999 (C)
 SPEED: 1.0 – 16.0(KM/H)
 INCLINE: 0-12%

9. HRC program:

A. When the treadmill stops, press the program to choose the HRC.

- a) .Press "M" to set the age, range 15-80 etc
- b). Press "M" to set the heart rate, range $80 - (220 - \text{age}) \times 0.9$
- c). Press "M" to set the time, then you can start the treadmill

B. Press the "START" key to start running

- a) Speed is 3.0km with no incline
- b) Run 1 minute at 3.0km/h
- c) Count the rate data (Target heart rate-user heart rate), and compare to 30 (follow below):
 - 1): (Target heart rate-user heart rate) >30 , then speed add 2.0km/h
 - 2): (Target heart rate-user heart rate) <30 , then speed add 1.0km/h
 - 3): (User heart rate-target heart rate) >30 , then speed less 2.0km/h
 - 4): (User heart rate-target heart rate) <30 , then speed less 1.0km/h
- d) Repeat the same action after 30 seconds
- e) The machine will slow down to 1km/h directly for 15 seconds and alert every second when the user heart rate is over the date $(220 - \text{age})$ at any time, then stop.
- f) The speed will not change if there is no heart rate sign or hand pulse. The machine will slow down to 1km/h directly for 15 seconds and alert every second

10. Body Fat test

At the beginning press " PROGRAM" continue entering FAT body fat test, window display "FAT" . Press "MODE" enter (F-1 SEX, F-2 AGE, F-3 HEIGHT, F-4 WEIGHT,), Press "SPEED+" , "SPEED—" to set. Press " MODE" to set F-5, grasp the hand pulse, the window will display your body quality index, The body quality index is to test the relation between height and weight.

The Body Fat test suits male and female users . The ideal Fat reading should be 20-25 if it reads under 19 it means you are too thin. If it reads between 25-29 it means that you are over weight and if the reading is over 30 it means that you are on the verge of obesity. (The data is just for reference and can not be used as medicinal advise)

01	Sex	01MALE 02 FEMALE	
02	Age	10-----99	
03	Height	0----200	
04	Weight	20-----150	
05	FAT	≤ 19	Under weight
	FAT	= (20---25)	Normal weight
	FAT	= (25---29)	Over weight
	FAT	≥ 30	Obesity

BELT ADJUSTMENT

BELT ADJUSTMENT

You may need to adjust the running belt during the first few weeks of use. All running belts are properly set at the factory. It may stretch or be off-center after use. Stretching is normal during the break-in period.

ADJUSTING THE BELT TENSION

If the running belt feels as though it is "slipping" or hesitating when you plant your foot during a run, the tension on the running belt may have to be increased.

TO INCREASE THE RUNNING BELT TENSION:

- A. Place 8MM wrench on the left belt tension bolt. Turn the wrench clockwise 1/4 turn to draw the rear roller and increase the belt tension.
- B. Repeat STEP A for the right belt tension bolt. You must be sure to turn both bolts the same number of turns, so the rear roller will stay square relative to the frame.
- C. Repeat STEP A and STEP B until the slipping is eliminated.
- D. Be careful not to tighten the running belt tension too much as you can create excessive pressure on the front and rear roller bearings. An excessively tightened running belt may damage the roller bearings that would result in bearing noise from the front and rear rollers.

TO DECREASE THE TENSION ON THE RUNNING BELT, TURN BOTH BOLTS COUNTER-CLOCKWISE THE SAME NUMBER OF TURNS.

CENTERING THE RUNNING BELT

When you run, you may push off harder with one foot than with another. The severity of the deflection depends on the amount of force that one foot exerts in the relation to the other. This deflection can cause the belt to move off-center. This deflection is normal and the running belt will centre when no body is on the running belt. If the running belt remains consistently off-center, you will need to centre the running belt manually.

- A). Start the treadmill without anyone on the running belt, press (SPEED UP) bottom until speed reaches 6kph.
- B). Observe whether the running belt is toward the right or left side of the deck.
 - a. If toward the left side of the deck
Using wrench, turn the left adjustment bolt clockwise 1/4 turn and the right adjustment bolt counterclockwise 1/4.
 - b. If toward the right side of the deck
Using wrench, turn the right adjustment bolt clockwise 1/4 turn and the left adjustment bolt counterclockwise 1/4.
 - c. If the belt is still not centered, repeat the above steps until the running belt is on center.
- C). After the belt is centered, increase the speed to 16kph and verify that it is running smoothly. Repeat the above steps if it is necessary.

If the above procedure is unsuccessful in resolving the off-center, you may need to increase the belt tension.

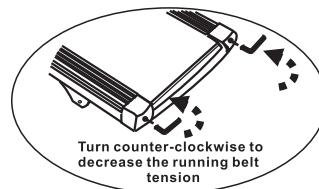
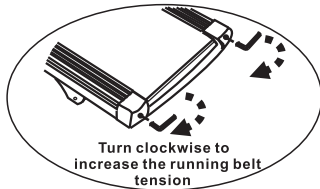

CARE & MAINTENANCE

WARNING! To prevent electrical shock, be certain the treadmill is turned off and unplugged before cleaning or routine maintenance.

RUNNING BELT AND RUNNING DECK LUBRICATION

For maximum treadmill life, this treadmill needs a routine lubrication as part of a general maintenance for the machine. The routine maintenance procedure will prevent premature wear of the running belt, running deck and drive motor system. The recommended lubrication schedule as:

USAGE	LUBRICATION
1~6kph	Every 3 months
6~12kph	Every 2 months
12~16kph	Every 1 month



Lubricant for running deck

This schedule is the recommended application for a single user, up to 20~30 minutes per time. 3~4 times per week. For lubrication, you can contact your dealer.

CLEANING

Perspiration should be wiped from the console and treadmill surface after your workout. You should wipe down your treadmill once a week with a water dampened, soft cloth. Be careful not get excessive moisture on the display panel as this might cause an electrical hazard or electronics to fail.

STORAGE

Store your treadmill in a clean and dry environment. Ensure the master power switch is off and is un-plugged from the electrical wall outlet.

MOVING

This treadmill has been designed and equipped with wheels for easy mobility. Before moving, ensure the master power switch is in the off position and the power cord is unplugged from the electrical outlet.

FOR CONSUMER/HOME USE ONLY!!

This treadmill is designed for home use only. Do not use for light institutional or commercial.

LUBRICATION MAINTENANCE

It is important to take good care of your treadmill deck (the walking surface underneath the belt). A good silicone lubrication will also improve the performance of your treadmill.

NOTE: Use the silicone that is supplied with the treadmill. Additional HEALTHSTREAM silicone lubricant can be purchased from your retail store.

WARNING: STOP the treadmill and remove the safety key before lubricating the running deck.

HOW TO SPRAY SILICONE ON DECK?

C). Spray silicone evenly on treadmill deck UNDER running belt as the drawing shows. (ATTENTION : The treadmill MUST BE STOPPED before applying the silicone lubricant. This is to prevent injury, otherwise the edge of the running belt may cut you or your fingers could be crushed by the rollers.)

Do not put too much silicone on the deck. Excessive lubricant may cause slippage of the belt on the rollers.

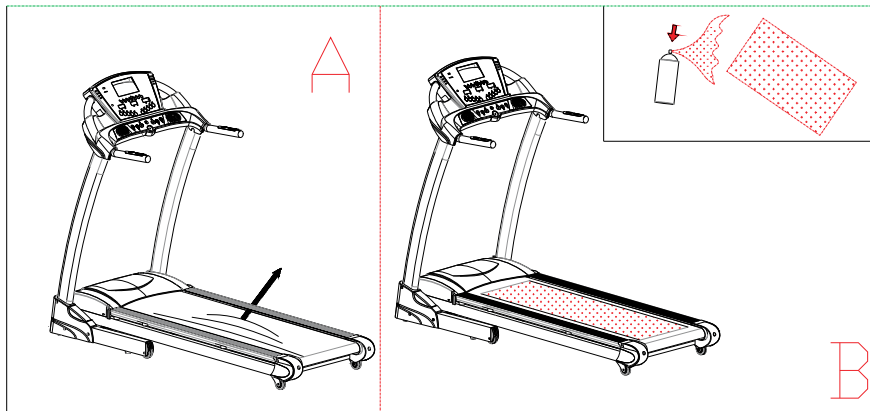

ERROR CODE AND SIGNIFICANCE

Fault Code	Fault Description	Fault Processing
E1	The computer has abnormal communication after starting	The control board stops and enters into error code. The console will display "E1" and beeps 3 three times
		Possible Reasons: Communication Abnormal: The control and computer has abnormal communication after starting. Check all the connection points between the console and controller, make sure every line is connected well. Check that all the wires are not damaged and if so, please call service department.
E2	The motor wire connection fault	The computer shows fault code "E2". After 10 seconds it will revert back to the ready mode and can be restarted. Possible reason; check that the motor wire is connected correctly and if not, please connect. If there is a burning smell, please contact service department.
	No Speed Wireless Sensor Network	The Computer shows fault code "E2". Other areas show blank. After 10 seconds will go into ready mode, and can restart. Possible Reasons: Can't receive the motor speed sensor feedback above three seconds, please check if the sensor plug is connected well or not. Connect the plug or change the sensor if yes.
E3	Current overload Protection	Computer shows fault code "E3". Other areas show blank. After 10 seconds, the treadmill will go into ready mode and can be restarted.
		Possible Reasons: An overloaded electrical surge will send the machine into self preservation mode. Check that there is no burning smell coming from the motor or controller, If yes, please call the service number located on the front cover of this manual.
E4	Incline self-learning fault	Check that the incline motor wire and AC wire are connected correctly; ensure the wire is not damaged. After this is completed, press the button on the controller and start the self learning
E5	Incline Sensor fault	Check the incline motor wire is connected well, and re-connect again. Check if the AC wire of incline motor is connected well, and make sure the AC wire is connected with the controller; check if the motor wire is damaged or not, call service department if yes. Press the button and start the self learning again
E6	Surge Protection: Some unusual power surge or voltage that causes damage to the motor drive circuit.	Start and stop fault status. The computer will buzz 9 times and show the "E6" code on the screen. Go into the ready mode and re start the treadmill.
		Possible reason: The power or voltage is not enough or the controller is faulty. Make sure that all of the wires are connected correctly

EXPLODED DRAWING

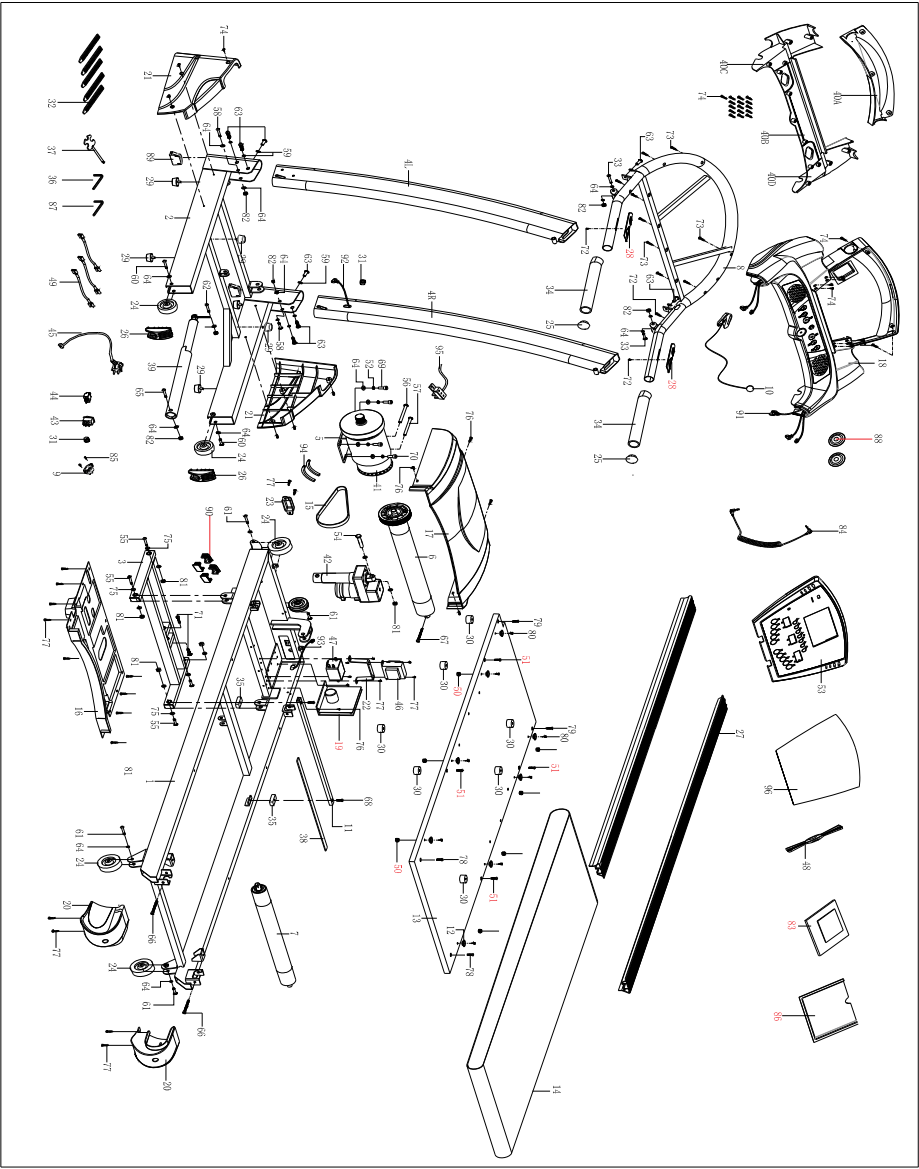

PARTS LIST

NO.	DESCRIPTION	REMARK	QTY	NO.	DESCRIPTION	REMARK	QTY
1	MAIN FRAME		1	22	BRACKET		1
2	BASE FRAME		1	23	SMALL COVER		1
3	INCLINE BRACKET		1	24	ADJUSTABLE WHEEL	Ø 9*Ø 62*23.5	6
4L/R	UPRIGHT		1	25	HANDLE BAR CAP		2
5	MOTOR BRACKET		1	26	WHEEL CASING PLUG	40*80*11.8	2
6	FRONT ROLLER		1	27	SIDE RAIL		2
7	REAR ROLLER		1	28	HAND PULSE		2
8	COMPUTER BRACKET		1	29	FLAT FOOD PAD		6
9	TAIL PLUG SOCKET		1	30	CUSHION	φ 30*φ 6.5*16	6
10	SAFETY KEY		1	31	RING PROTECTED WIRE PLUG		2
11	RUNNING STRENGTH TUBE		1	32	CABLE TIE		5
12	WASHER		8	33	HALF ROUND HEAD HEX BOLT	M8*45	2
13	RUNNING BOARD		1	34	HANDRAIL FOAM		2
14	RUNNING BELT		1	35	CUSHION		2
15	MOTOR BELT	200-J7	1	36	ALLEN WRENCH	S5	1
16	MOTOR BOTTOM COVER		1	37	SCREW DRIVER		1
17	MOTOR TOP COVER		1	38	EVA CUSHION	13.0*20*565	1
18	COMPUTER		1	39	CYLINDER		1
19	CONTROLLER		1	40	COMPUTER BOTTON COVER	A/B/C/D	4
20	END CAP		2	41	DC MOTOR		1
21	SIDE COVER		2	42	INCLINE MOTOR		1

PARTS LIST

NO	DESCRIPTION	REMARK	QTY	NO.	DESCRIPTION	REMARK	QTY
43	POWER SWITCH		1	63	HALF ROUND HEAD HEX BOLT	M8*15	8
44	OVERLOADED SWITCH		1	64	FLAT WASHER	Ø 9*Ø 16*t 1.6	20
45	POWER CORD		1	65	HALF ROUND HEAD HEX BOLT	M8*45	1
46	INDUCTOR		1	66	ROUND HEAD HEX BOLT	M6*60	2
47	FILTER		1	67	ROUND HEAD HEX BOLT	M6*45	1
48	CHEST BELT		1	68	ROUND HEAD HEX BOLT	M6*15	2
49	SINGLE WIRE		3	69	ROUND HEAD HEX BOLT	M8*35	2
50	HEX NUT	M5	6	70	ROUND HEAD HEX BOLT	M8*20	2
51	HALF ROUND HEAD HEX BOLT	M6*35	4	71	ROUND HEAD HEX BOLT	M10*30	2
52	SPRING WASHER	Ø 8.1*Ø 12 .3*12.1	6	72	CROSE FLAT HEAD BOLT	ST4*35	2
53	COMPUTER PANEL		1	73	CROSS FLAT HEAD BOLT	ST4*25	6
54	HEX BOLT	M10*45	1	74	CROSE FLAT HEAD BOLT	ST4*15	28
55	HALF ROUND HEAD HEX BOLT	M10*45	4	75	FLAT WASHER	Ø 11*Ø 20 *12	10
56	ROUND HEAD HEX BOLT	M8*85	1	76	GASKET HEAD BOLT	M5*10	7
57	ROUND HEAD HEX BOLT	M8*75	1	77	GASKET HEAD SELF TAPPING BOLT	M4*15	24
58	HALF ROUND HEAD HEX BOLT	M8*60	2	78	COUNTERSUNK HEAD BOLT	M6*25	2
59	INNER WASHER	Ø 8.4*Ø 14 .5*10.8	8	79	COUNTERSUNK HEAD BOLT	M6*45	6
60	HALF ROUND HEAD HEX BOLT	M8*50	2	80	COUNTERSUNK HEAD BOLT	M5*30	8
61	HALF ROUND HEAD HEX BOLT	M8*40	4	81	LOCKNUT	M10	5
62	HALF ROUND HEAD HEX BOLT	M8*25	1	82	LOCKNUT	M8	8

PARTS LIST

NO	DESCRIPTION	REMARK	QTY	NO	DESCRIPTION	REMARK	QTY
83	UPPER CONTROLL BOARD		1	91	COMPUTER UPPER WIRE		1
84	MP3 LINE		1	92	COMPUTER MIDDLE WIRE		1
85	COUNTERSUNK HEAD BOLT	ST4.0*10	2	93	COMPUTER BOTTOM WIRE		1
86	MANUAL STORAGE		1	94	MOTOR CUSHION BLOCKING		2
87	ALLEN WRENCH	S6	1	95	SENSOR		1
88	SPEAKER		2	96	COMPUTER OVERLAY		1
89	FOOT PAD		2				
90	INCLINE BRACKET PLUG		4				